

RAY70

Technical Manual



-Table of Contents-

- PREFACE
- RAYPOS TECHNICAL MANUAL REVISION HISTORY
- COPYRIGHT
- WARRANTY
- SAFETY INSTRUCTIONS
- SPECIFICATION
- 1) SPECIFICATION – OUTSIDE SIZE
- 2) BODY EXPLODE VIEW
- 3) MODULE EXPLODE VIEW
- 4) MONITOR EXPLODE VIEW

1. PRODUCT OVERVIEW

- 1) INSIDE YOUR PACKAGE
- 2) PRODUCT OUTLINE
- 3) CONFIGURATION
- 4) I/O PORT: DETAILS
- 5) SETTING UP: CONNECTION VIA ETHERNET PORT(LAN)
- 6) SETTING UP: USB PORT CONNECTION
- 7) SETTING UP: SERIAL PORT (DUSB9)
- 8) SETTING UP: POWER CABLE CONNECTION
- 9) SETTING UP: MAIN POWER SWITCH(POWER S/W)

2. INSTALLATION INSTRUCTIONS

- 1) ADAPTER AND PORT
- 2) PRODUCT
- 3) BASE PLATE
- 4) WALL BRACKET(VESA)
- 5) WALL INSTALLATION INSTRUCTION
- 6) PRINTER PAPER RELOAD
- 7) DEVICE OFF AND SLEEP MODE
- 8) NFC READER
- 9) BARCODE READER

3. RAYPOS MODULE KIOSK SYSTEM SEPARATION

- 1) SEPARATING LCD MODULE
- 2) SEPARATING PRINTER MODULE
- 3) SEPARATING NFC READER MODULE
- 4) SEPARATING QR READER MODULE
- 5) SEPARATING MOTHERBOARD

4. MOTHERBOARD

- 1) MOTHERBOARD OVERVIEW
- 2) MOTHERBOARD LAYOUT

5. TROUBLE SHOOTING

- 1) NETWORK ISSUES
- 2) USB ISSUES
- 3) LCD ISSUES
- 4) TOUCH – SCREEN ISSUES
- 5) POWER & BOOTING ISSUES

6. MAINTENANCE

Preface

This User's Guide gives information about main unit/IO port layout, basic setup, component installation, and board layout for point of sale system "RAYPOS"

Intended Audience

The User's Guide is intended for technically qualified personnel. It is not intended for general audiences.

Document Organization

The chapters in this Product User's manual are arranged as follows:

1. product package contents
2. system configuration
3. Harness (cable connector)
4. Installing and Replacing POS SYSTEM Components: instructions on how to install the motherboard and other POS hardware components.
5. Product specification

RAYPOS Technical Manual Revision History

Changes to the RAYPOS Technical manual are listed below.

No.	Revision date	Revision History
01		
02		
03		
04		
05		
06		
07		
08		
09		
10		

Copyright

This publication, including all photographs, illustrations and software, is protected under international copyright law with all rights reserved to the manufacturer. Neither this manual, nor any of the material contained herein, may be reproduced without express written consent of the author.

RAYPOS Co., Ltd. are trademarks in the South Korea and other countries.

*Other names and brands may be claimed as the property of others.

Copyright RAYPOS Co., Ltd. All rights reserved.

Warranty

We guarantee our POS terminal product and its parts against defects in materials and workmanship, under proper use, for a standard period of 1year from the original date of purchase.

Products out of the warranty period or scope shall be diagnosed at the customer's expense.

In the case of product damage due to error on part of the consumer, incorrect usage, carelessness or natural phenomenon, the customer shall bear the full cost for both repair and delivery.

Safety Instructions

The RAY70 product is an electronic device that uses precision components.

To ensure stable and normal operation, please pay attention to the following points:

1. When moving the product, turn off the main power switch and unplug the main power cord connected to the product.
2. Do not place the product face down on the floor, as this may damage the screen.
3. When installing the product, ensure it is not placed on a sloped or unstable surface.
4. Secure the product to prevent it from falling over during installation.
5. Do not install the product near kitchens or countertops, as oil or vapor can cause damage or deformation.
6. Install the product in a location that can adequately support its weight.
7. Ensure the installation area is well-ventilated.
8. Avoid using the product in high-temperature, humid environments or under direct sunlight.
9. Do not subject the product to impact.
10. Do not connect the product to main power sources with high energy consumption.
11. Avoid placing objects on top of the product or spilling liquids like beverages or water on it, as this may cause malfunction or damage.
12. When unplugging or plugging in the main power cord, turn off the main power switch and handle the plug by its grip.
13. When cleaning the device, turn off the main power and wipe it with a dry cloth. Do not use chemicals like alcohol, solvents, surfactants, wax, benzene, thinner, insect repellent, air freshener, lubricant, or cleaning agents, as they can cause discoloration, cracking, peeling, or erasure of markings on the product's surface.
14. When disassembling the product, always turn off the main power and remove the main power cable from the main unit before proceeding.
15. When connecting the rear monitor, ensure the main power is off.
16. Use standard adapters and cables.
17. If the device malfunctions or does not operate correctly, please contact the customer service center.
18. If you notice strange noises, a burning smell, or smoke coming from the product, immediately unplug the main power cord and contact the customer service center.
19. If the product is dropped or the exterior is damaged, turn off the main power, unplug the main power cord, and contact the customer service center.
20. Do not disassemble or modify the product yourself. Please contact the customer service center for assistance.

Specification

RAY70		
Processor		4 x Cortex-A55 core, 2.0GHz
O/S		Android 13 or Linux
Memory		eMMC 16GB(up to 128GB) / DDR4 2GB(up to 4GB)
Display	Resolution	15.6", TFT Color 1920 x 1080 px (LED Backlight)
	Touch Screen	Capacitive Touch Panel
WiFi		802.11 a/b/g/n/ac/ax
Bluetooth		BLE 5.2
Peripheral ports	USB	Rear2 (USB 2.0 x 2 ports), Front2 (USB 3.0 x 2 ports)
	Parallel	DSUB9 serial x 1
	LAN	RJ45 Serial x 1
	Power	DC Jack x 1 (Power DIN 4P)
Printer	Size	3" Thermal
	Speed	220mm/s
	Resolution	203dpi
NFC Reader	Peripheral ports	5 PIN Wire Cable
		4 PIN Gold Plate Terminal
	Certification	ISO14443 Type A, Type B, Mifare, Felica, EMV Contactless L1, L2(MCL, VCL, AMEX, JCB, CUP)
Barcode Reader		1D/2D Reader, CMOS Camera, 640×480 pixel
Sound		5W x 2 Speaker
Operating Temperature		0°C to +50°C
Power		24Vdc@2.5A
Dimension (W x D x H)		279mm x 225mm x 672.3mm
Certification		CE, FCC, RoHS

Specification – Outside size

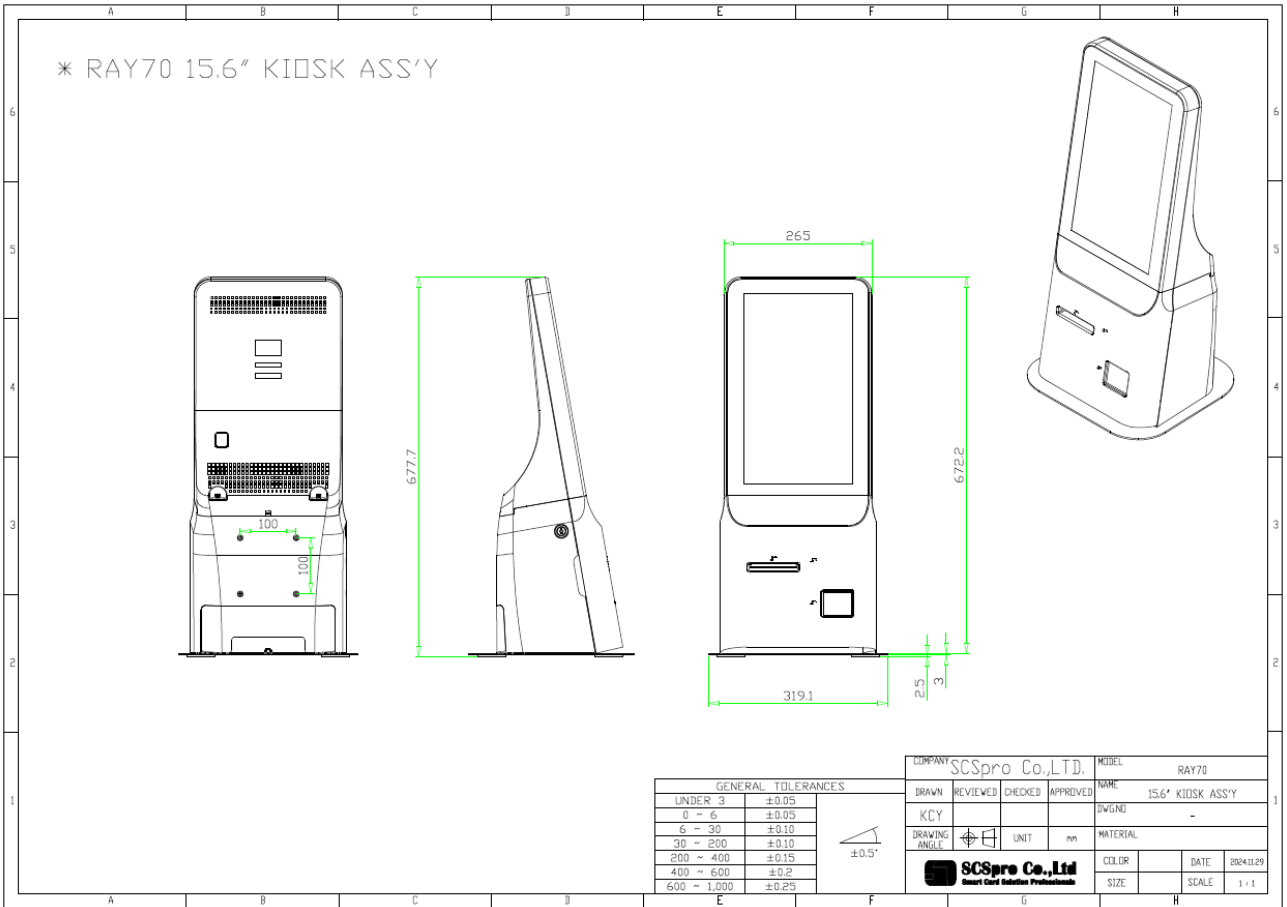

Specification – Body Exploded view

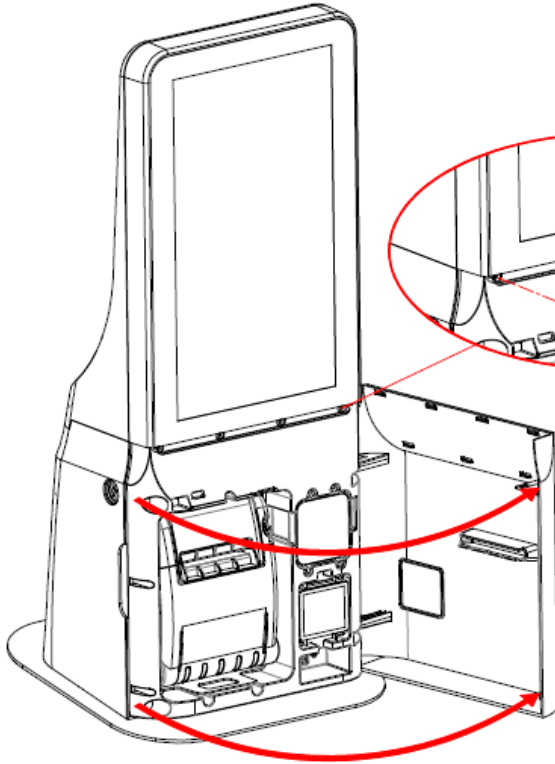

Machine Screw
Pan Head 3 x 10mm – 4ea

Machine Hand Screw
4 x 8mm – 2ea

Machine Screw
Pan Head 3 x 10mm – 4ea

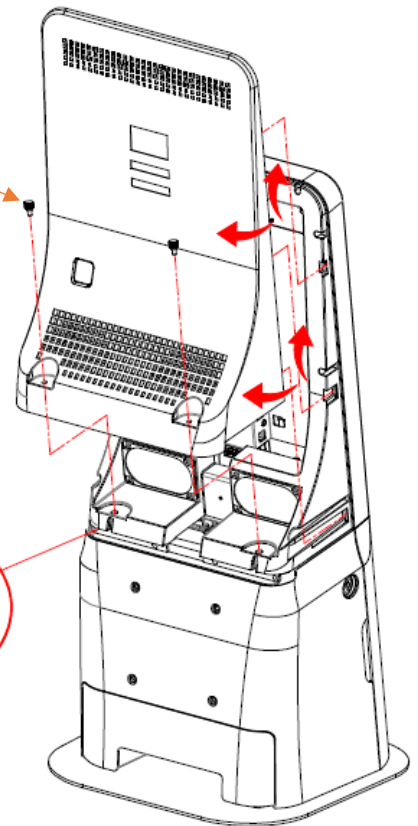
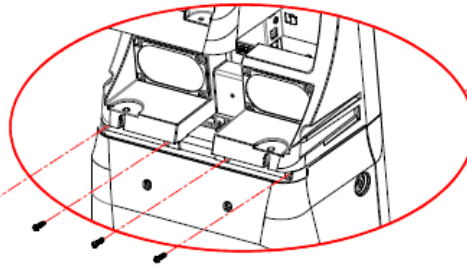

Specification – Module Exploded view

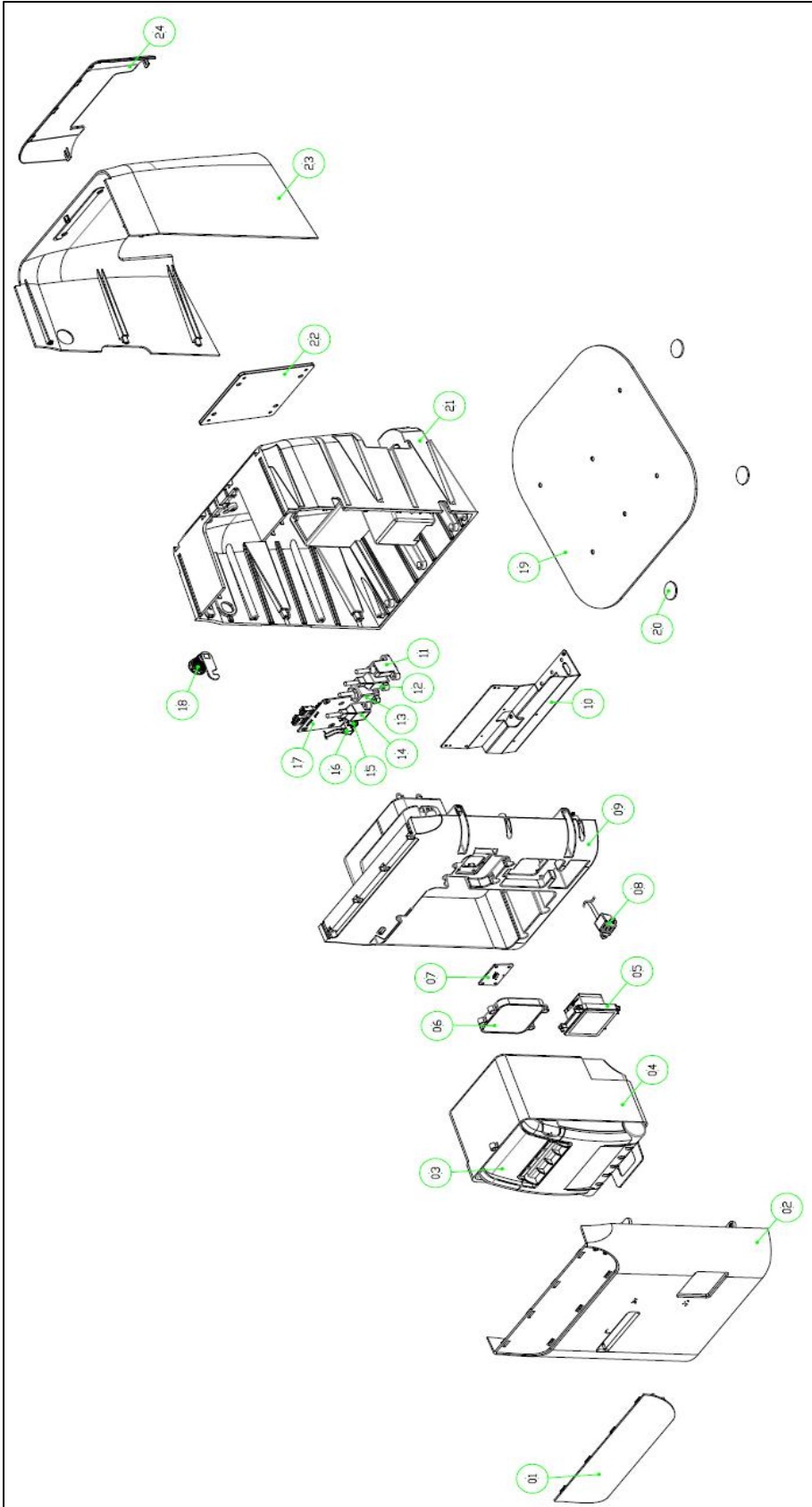

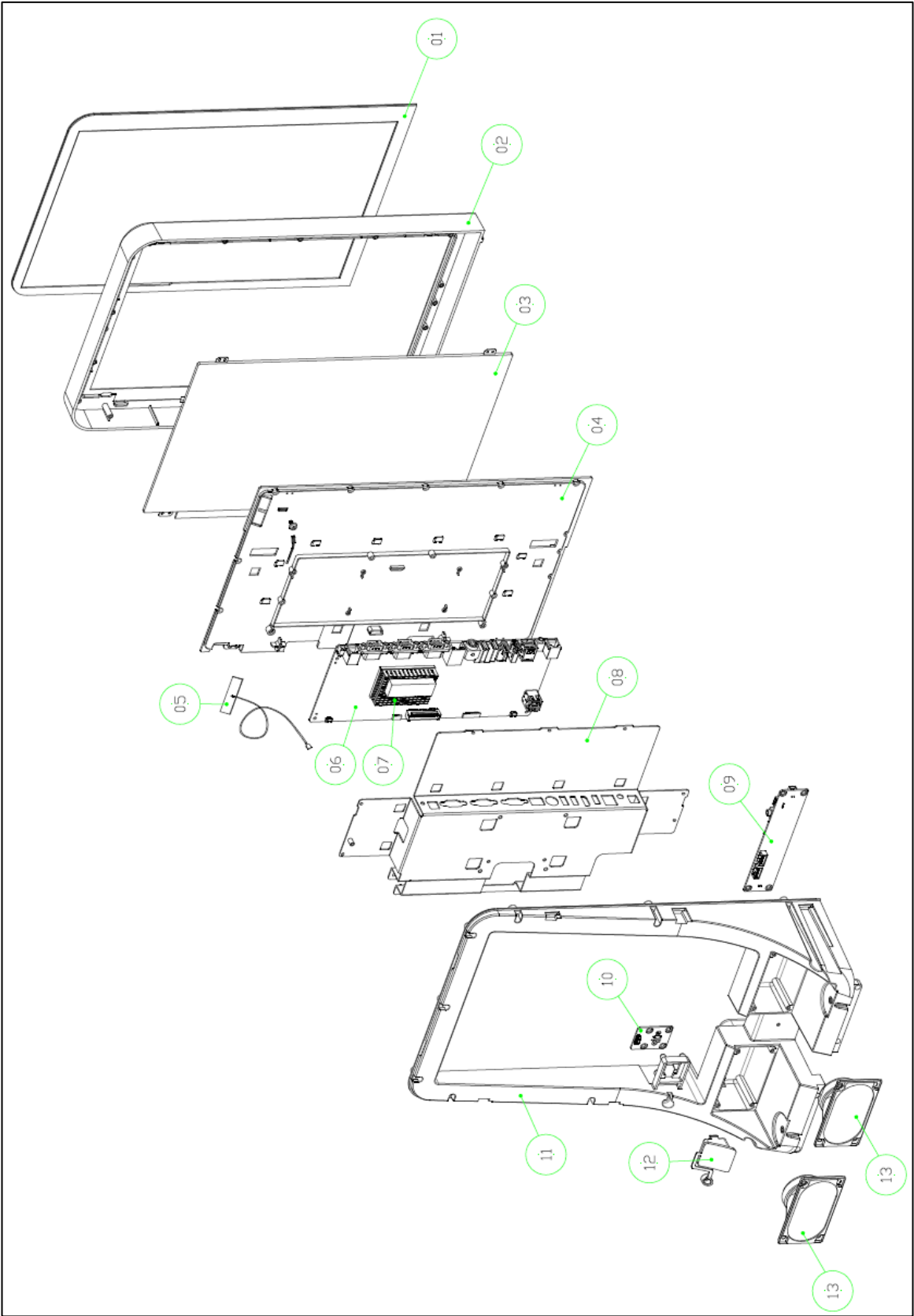

Specification – Monitor Exploded View



1. Product Overview

(1) Inside Your Package

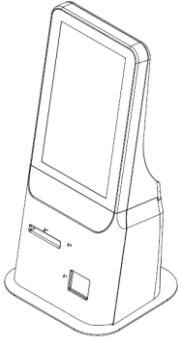
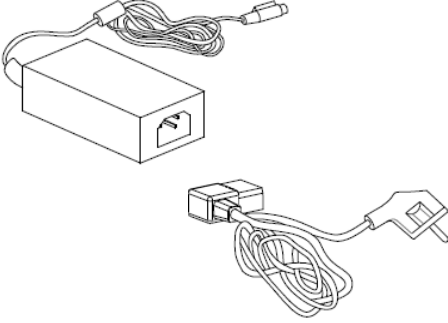
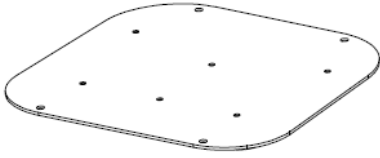
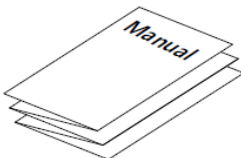
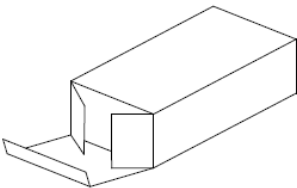
1. Please check your package and confirm its contents.
2. The POS terminal main unit, power cable and user manual are included in the package.
If any items are missing or damaged, please contact your dealer for assistance.
» All user manuals are available for download on our website: www.rayposww.com

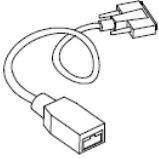
RAYPOS Main Unit	Adapter / Power cord
	
Base Plate	Installation Guide
	
Accessory Box	Key
	
Machine Screw M5x12mm – 6pcs (Base plate)	Gender Cable
	

(2) Product Outline

- Each part of product may differ depending on the specific POS model.
- Model-specific data sheets are provided on our website at www.rayposww.com

(3) Configuration

Refer to following diagram to identify the components on this side of the system.

Front view

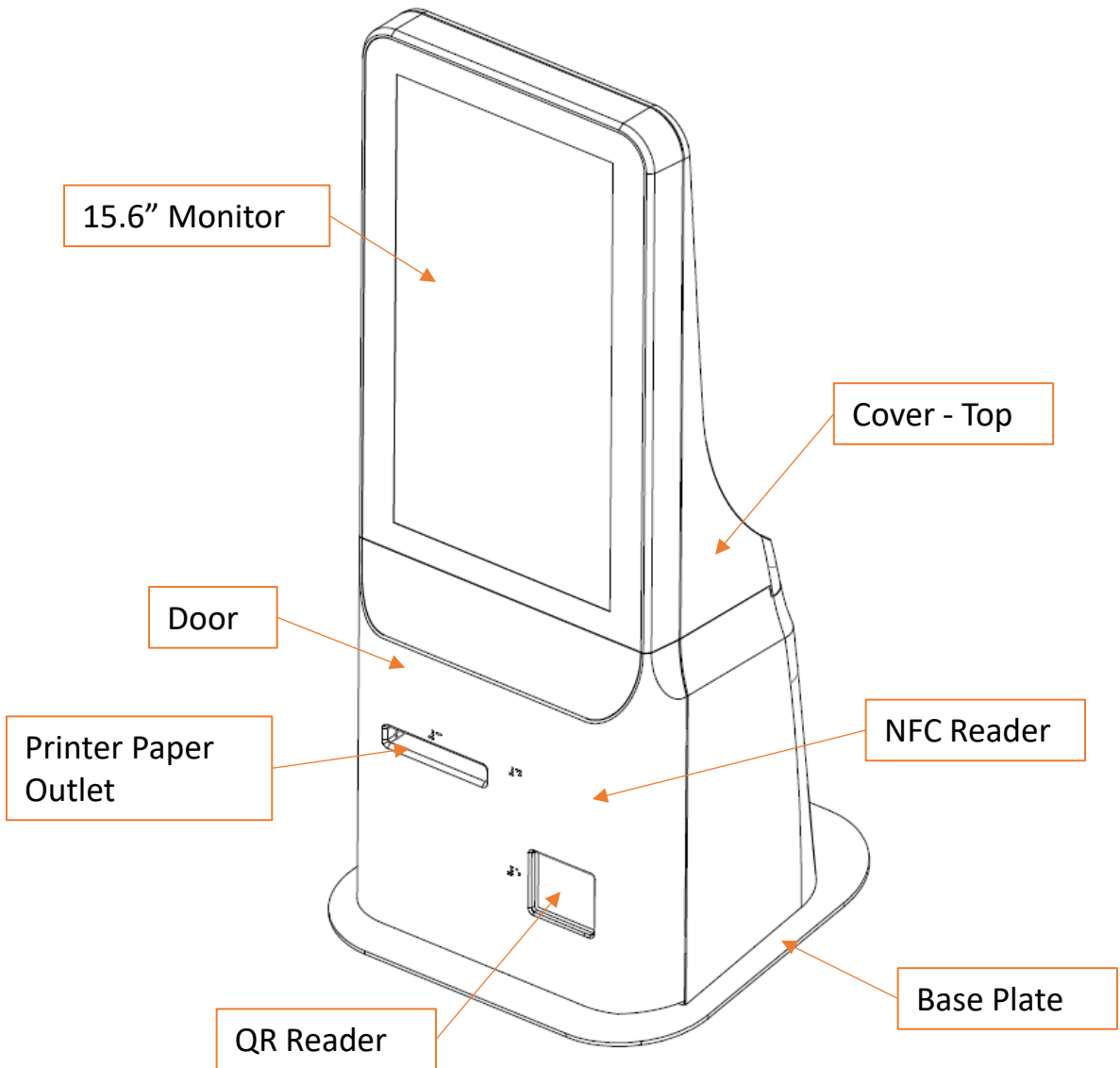

Rear view

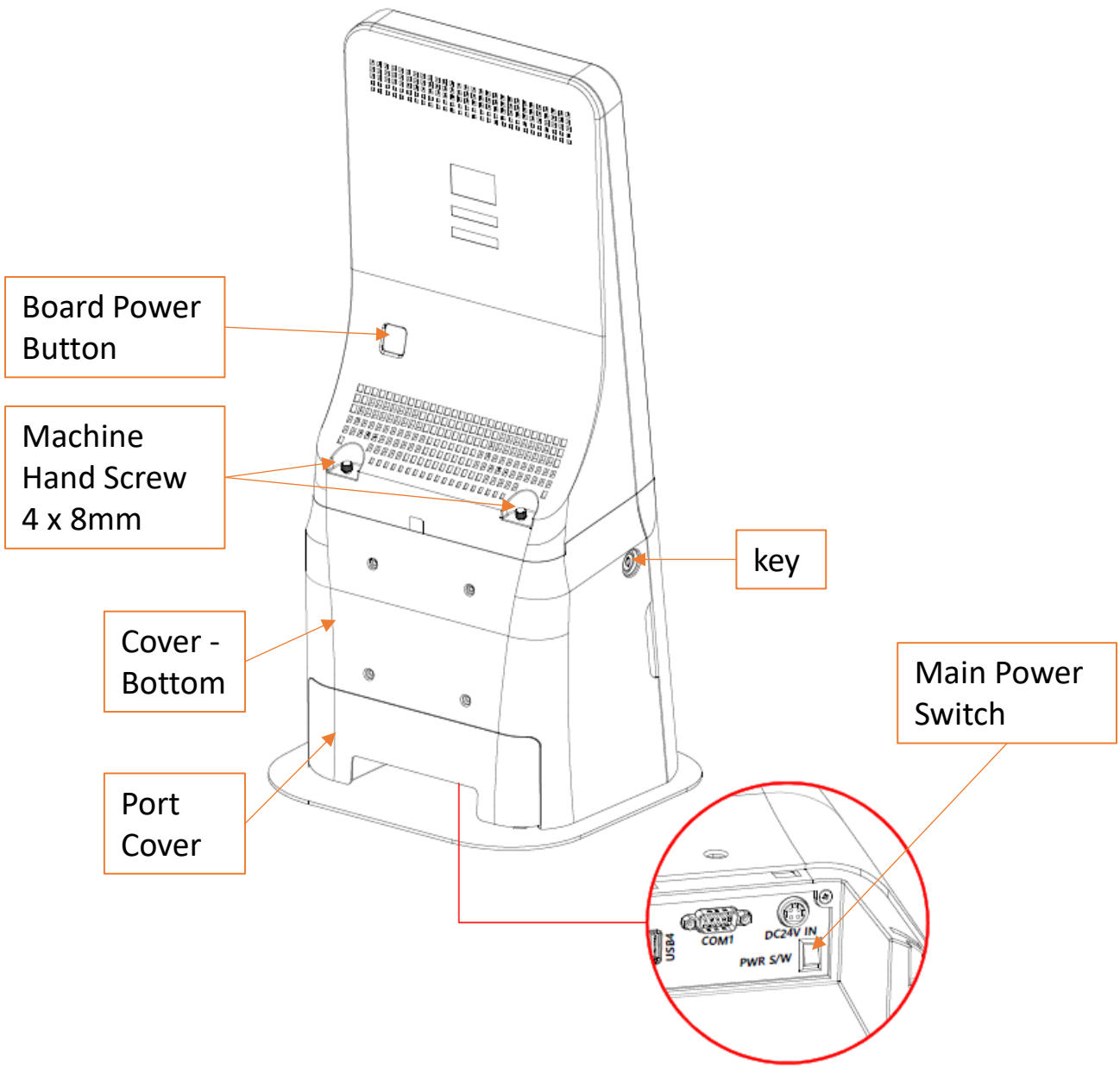

(4) I/O port : Details

* I/O ports may differ according to product model or options.

I/O front view

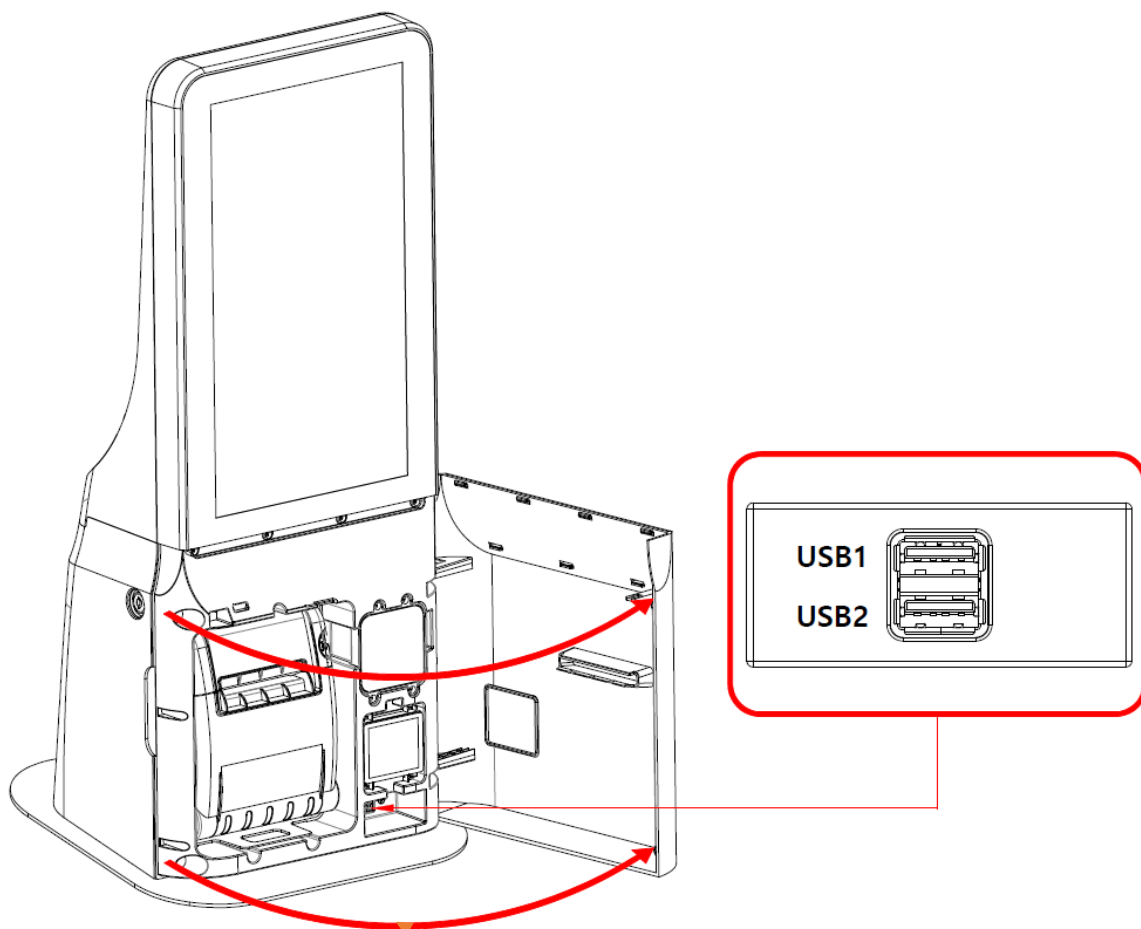

Please open the door in the direction of the arrow.

I/O Rear view

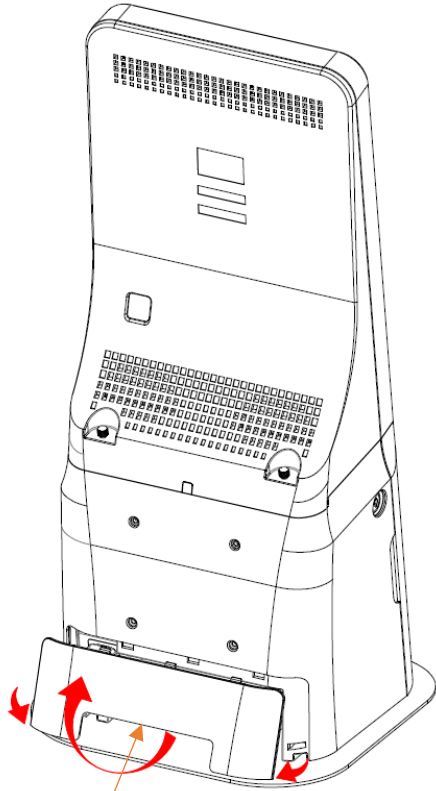

Port cover
handle groove

Insert your hand into the handle groove of the cable cover, grip the cover, and open it in the direction of the arrow.

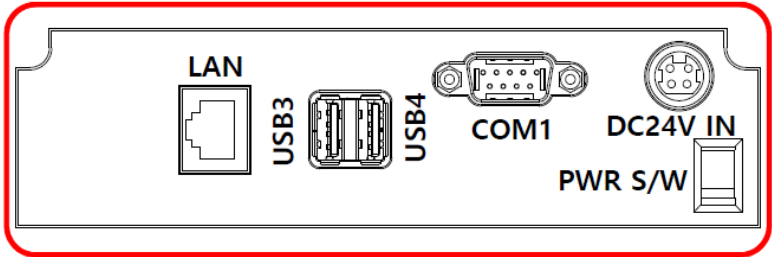
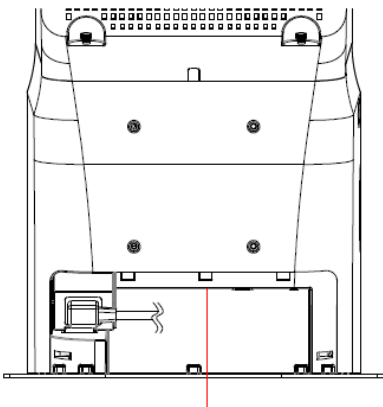

Front Ports

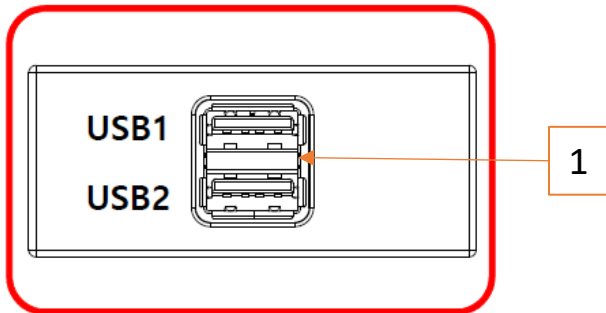

1. USB1, USB2 : USB3.0 connection 2ports

Rear Ports

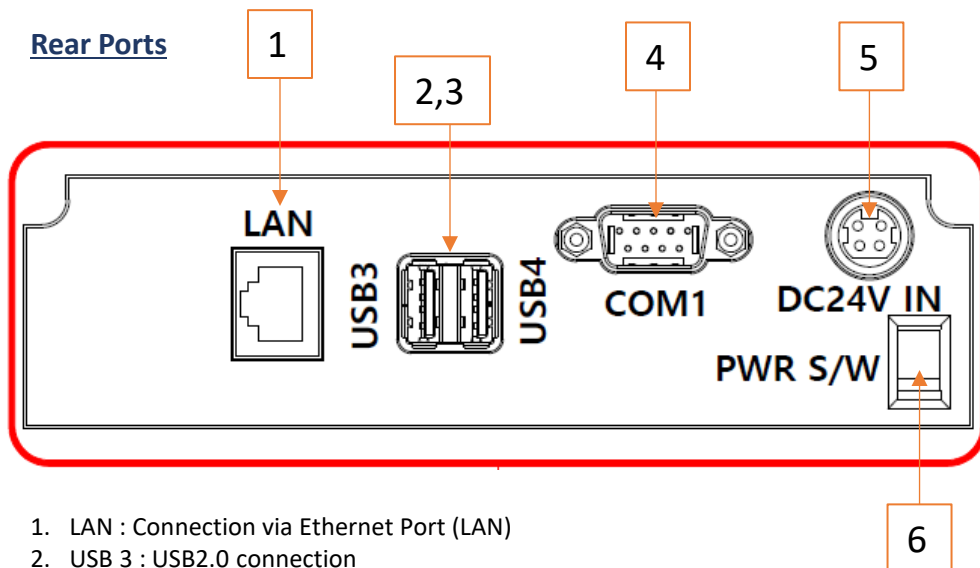

1. LAN : Connection via Ethernet Port (LAN)
2. USB 3 : USB2.0 connection
3. USB 4 : USB2.0 connection
4. COM1 : Serial Port (RS232)
5. DC24V-IN : Power cable connection port
6. PWR S/W : Main power switch

(5) Setting up : Connection via Ethernet Port (LAN)

The Ethernet port located on the rear I/O supports 10/100/1000Mbps using an RJ45 connector cable.

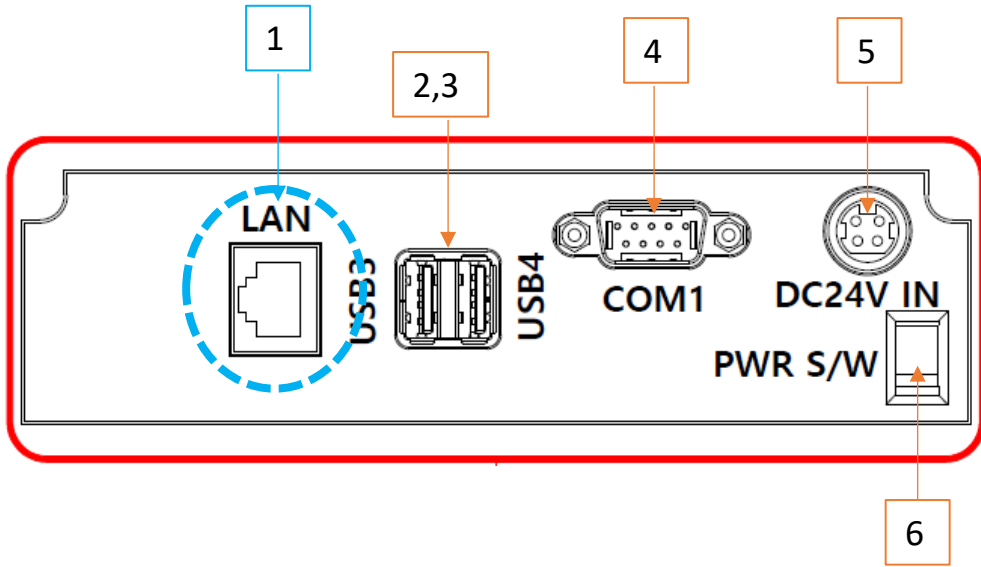

LAN port Specification				
Pin	I/O	Name	FUNCTION	
1	O	TX+	Transmit Data+	
2	O	TX-	Transmit Data-	
3	I	RX+	Receive Data+	
4	-	-	-	
5	I	RX-	Receive Data-	
6	-	-	-	
7	-	-	-	
8	-	-	-	

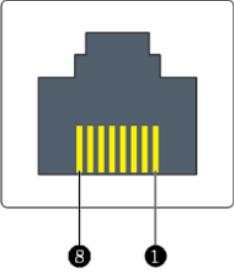

(6) Setting up : USB Port Connection

USB ports are provided in the KIOSK unit, with two at the front I/O supporting the standard USB 3.0. Additionally, two USB 2.0 ports are provided at the rear I/O.

Front

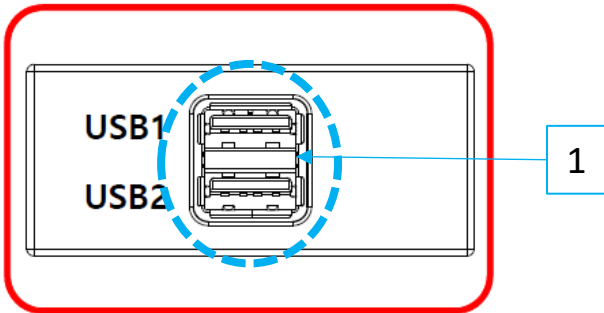

Rear

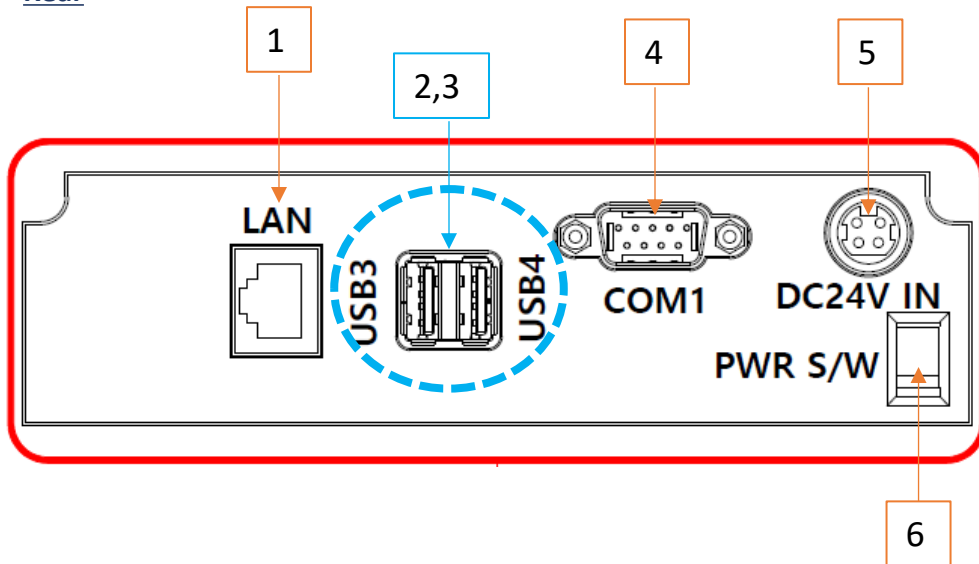

USB 2.0 Port & USB 3.0 Port Specification				
	Pin	I/O	Name	FUNCTION
	1	P	Vusb	+5V
	2	IO	D-	Data-
	3	IO	D+	Data+
	4	P	GND	Ground

(7) Setting up : Serial Port (DSUB9)

Connect the Serial port on the rear of the device.

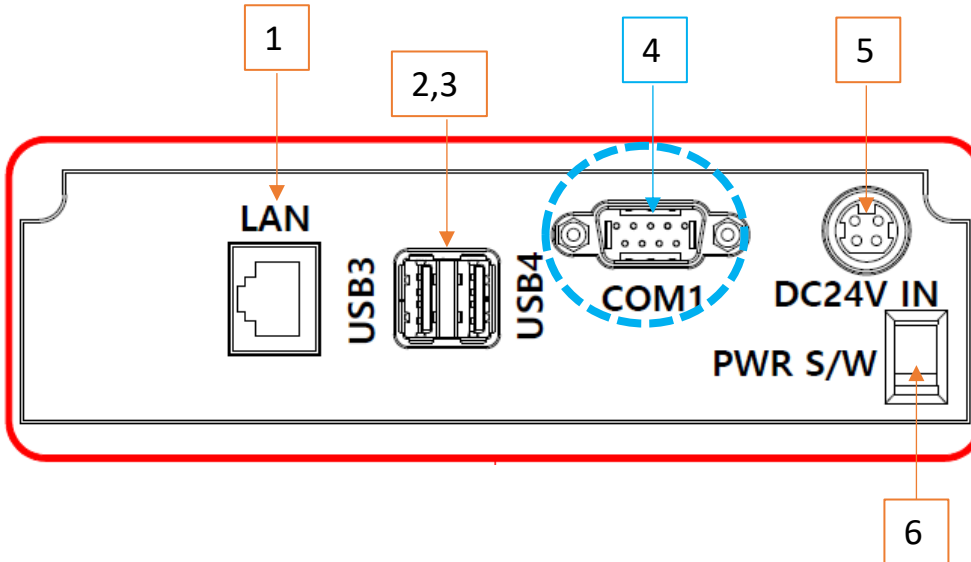

DSUB9 Specification				
	Pin	I/O	Name	FUNCTION
	1	-	-	-
	2	I	RXD	Receive Data
	3	O	TXD	Transmit Data
	4	-	-	-
	5	P	GND	GND
	6	-	-	-
	7	-	-	-
	8	-	-	-
	9	P	Power(DC5V)	Power supply terminal, Power On/Off control possible

(8) Setting up : Power Cable Connection

The 'RAYPOS' POS system is equipped with a 24Vdc/ 2.5A power adapter. Connect the cable to the DC-IN port on system IO panel.

CAUTION : Do not pull on the adaptor cable! Disconnect cable by pulling the plug cap.

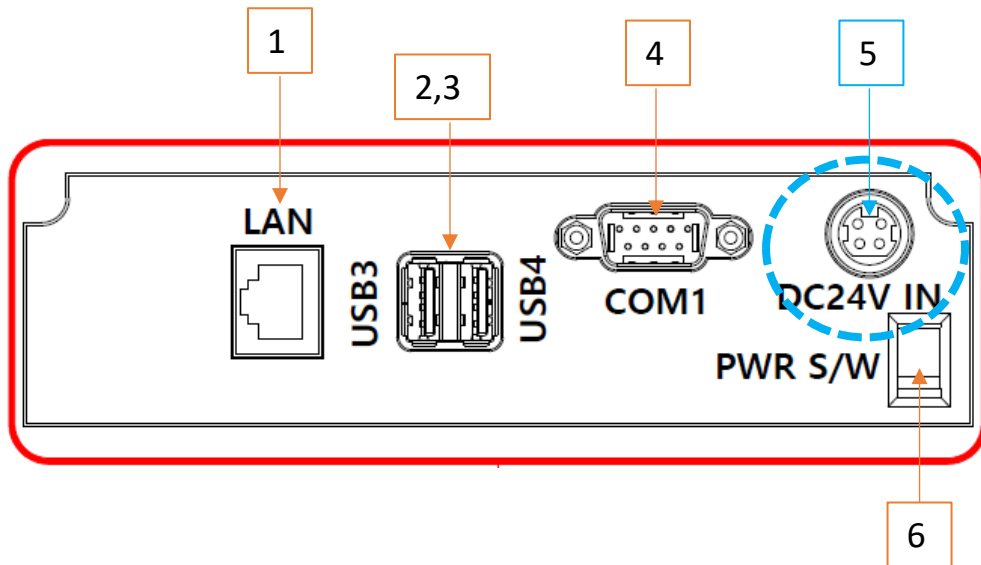

Power (Input) port / Adapter Input – 24V Specification				
	Pin	I/O	Name	FUNCTION
	1	P	+24VDC	+DC 24V
	2	P	+24VDC	+DC 24V
	3	P	GND	Ground
	4	P	GND	Ground

(9) Setting up : Main Power Switch (Power S/W)

The main power switch is located at the back of the device.

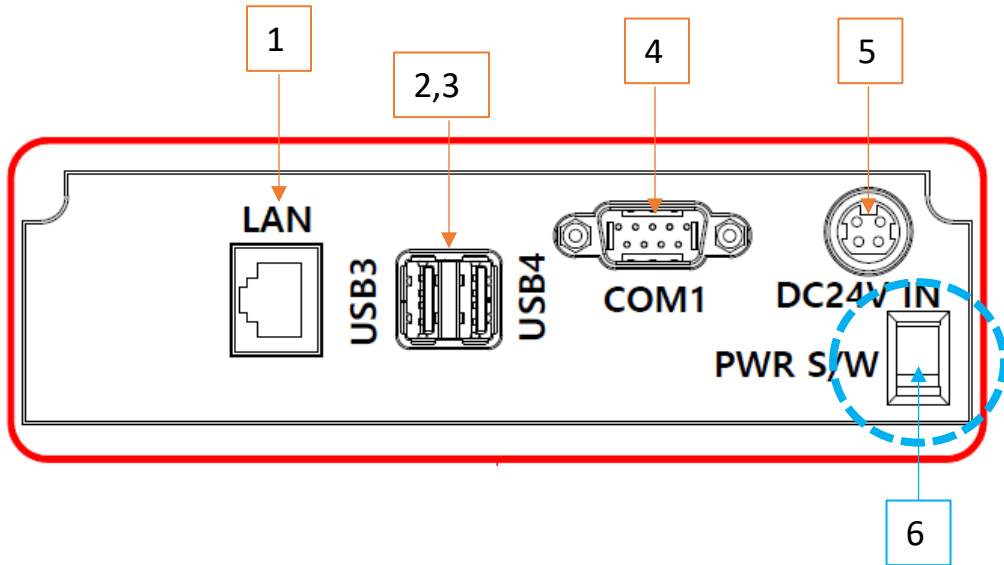

2. Installation Instruction

(1) Adaptor and Port

1. Lift the handle of the rear lower cable cover to remove the cover.

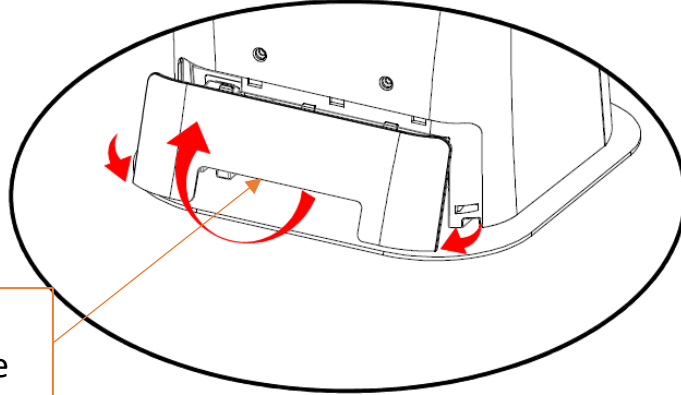

Port cover
handle groove

2. Connect the DC jack of the adapter.

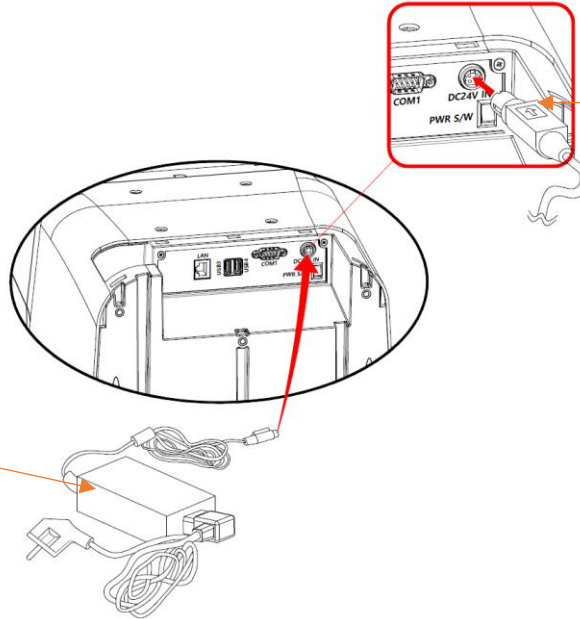

Caution:
Direction of
the adapter
power cable

Adapter

3. When storing the adapter, please refer to the illustration above.

After plugging in the
adapter power cable,
insert the adapter in the
direction of the arrow

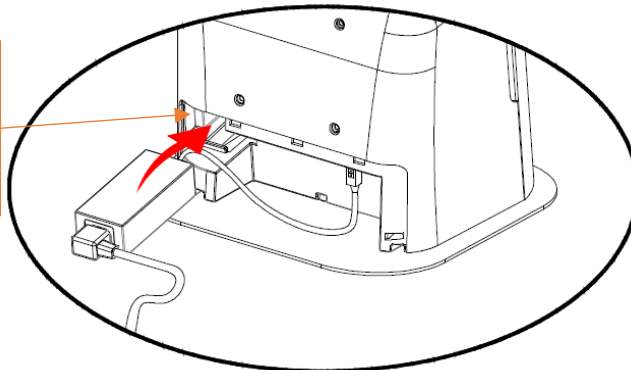

(2) Product

1. Place the device securely in the desired location.
2. Plug in the power cord. (This product supports Free Voltage)

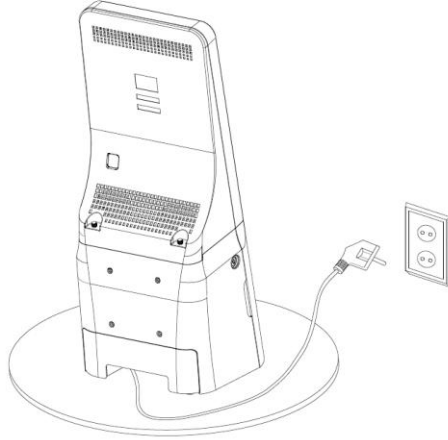

3. Turn on the power switch of the device.

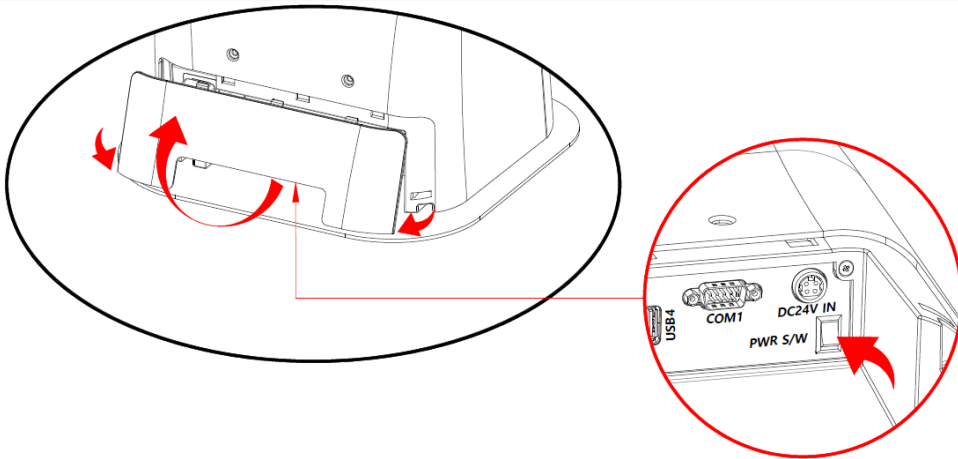

4. When the terminal is off, briefly press the board power button to turn on the product.

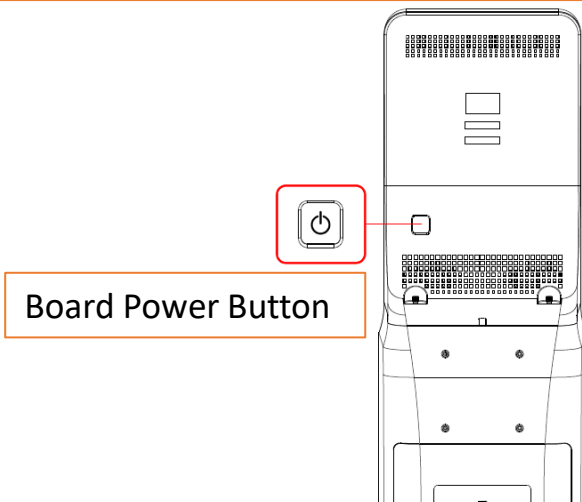

(3) Base Plate

Machine Screw
Flat Head
5 x 12mm – 6ea

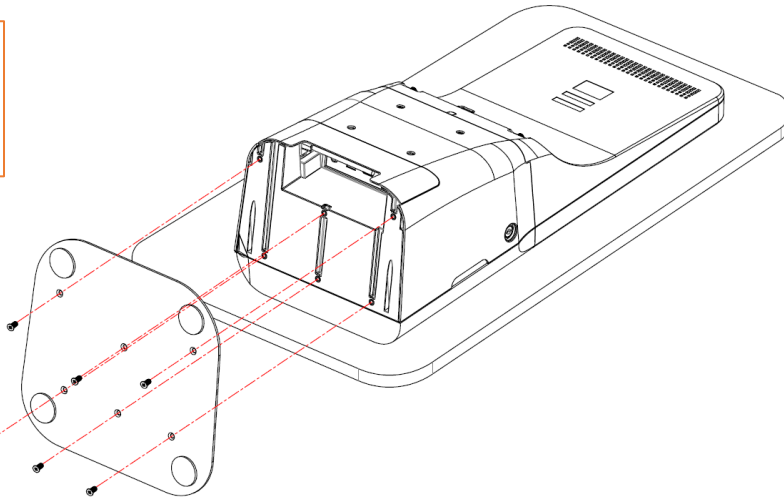

Please assemble and use the product as shown below using the M5 x 12mm countersunk screws provided.

(4) Wall Bracket(VESA)

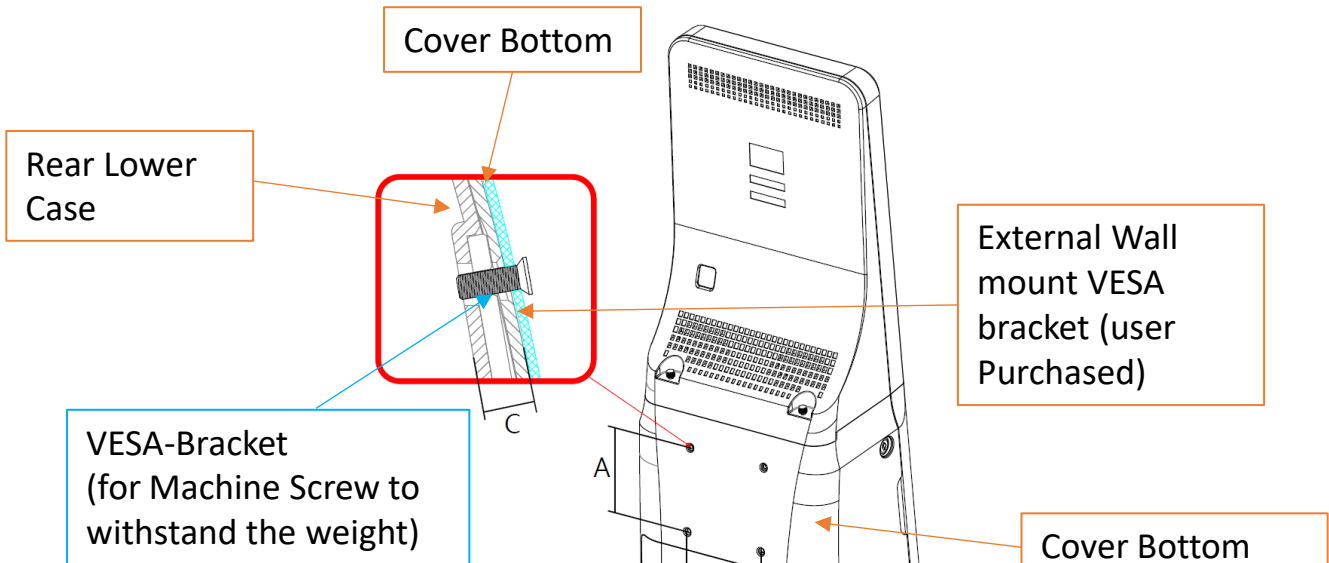

VESA Dimension (Amm * Bmm)	100 X 100
'C' Screw length (mm)	7.0(Minimum) – 9.5(Maximum)
Standard Screw	M5
Quantity	4ea

(5) Wall Installation Instruction

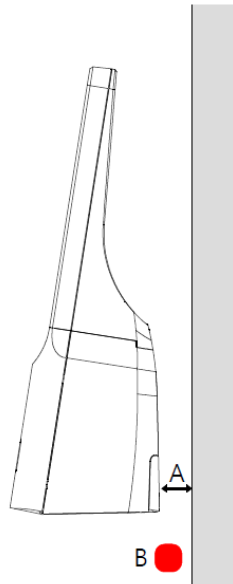

1. Vertical Wall-Mount Installation Conditions:

- A Minimum: 15mm
- B Ambient Temperature Measurement Point: $\leq 0^{\circ}\text{C}$ to 35°C

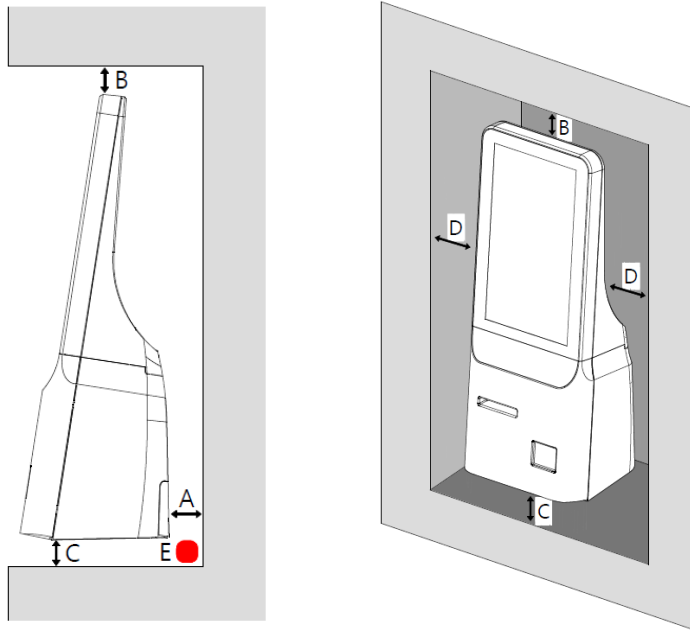

2. Recessed Wall-Mount Installation Conditions:

- A Minimum: 15mm
- B Minimum: 25mm
- C Minimum: 0mm
- D Minimum: 60mm
- E Ambient Temperature Measurement Point: $\leq 0^{\circ}\text{C}$ to 35°C

(6) Printer Paper Reload

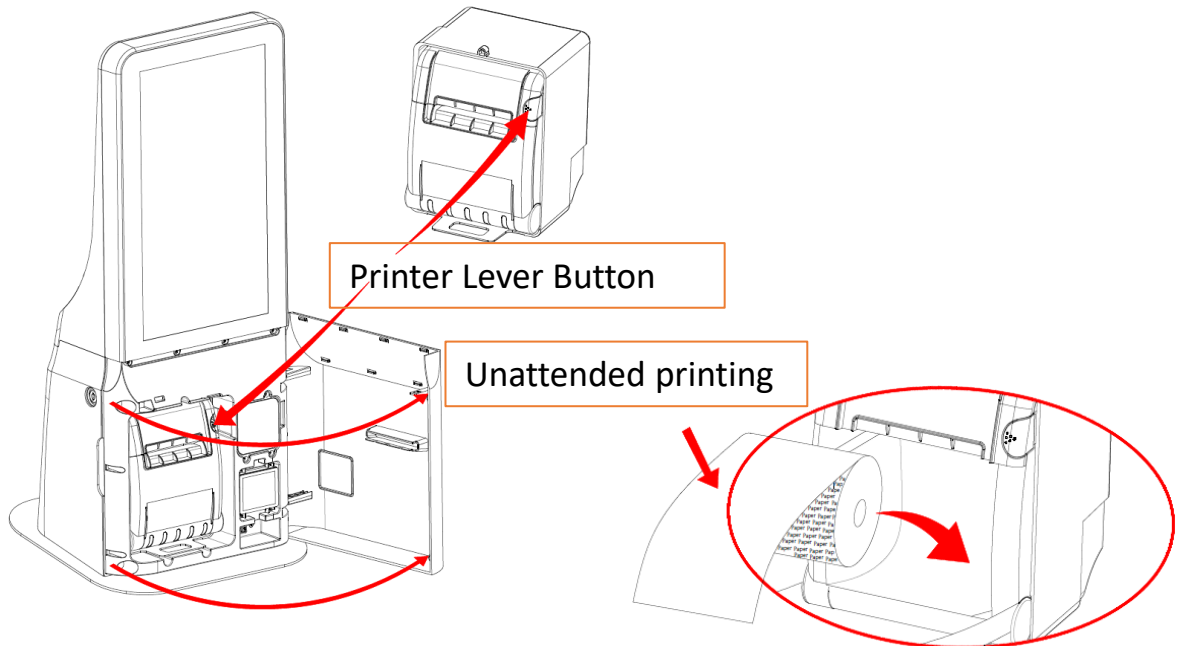

1. Please open the door.
2. Press the printer button to open the printer paper cover.
3. Load the paper according to the direction and then close the printer paper cover.
4. After the auto-cut is performed once, please close the door.
(The auto-cut will be performed once if the printer is powered on.)

(7) Device Off and Sleep Mode

- Device OFF

While the device is ON, press and hold the board power button to activate

menu at the top of the front screen.

Touch to turn off the device.

- Sleep Mode (The LCD screen turns off when entering sleep mode.)

While the device is ON, briefly press the board power button to enter sleep mode.

Briefly pressing the board power button will end sleep mode.

(8) NFC Reader

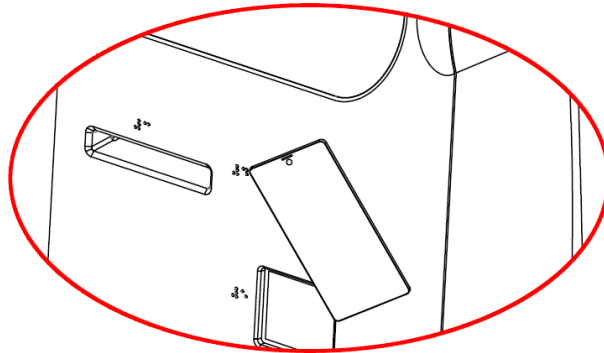

1. Place the NFC card or smartphone on the NFC reader, and it will automatically read the card.
2. Do not remove the NFC card or smartphone until the NFC reading is complete.

(9) Barcode Reader

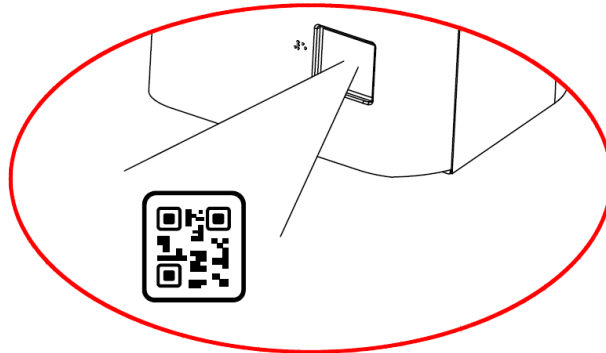

1. When scanning the QR code with a smartphone, set the screen brightness to the maximum.
2. Place the QR code at a certain distance from the reader window, and it will be automatically read.
3. Do not remove the QR code until the reading is complete.

3. RAYPOS Module KIOSK System Separation

(1) Separating LCD module

- Warning : Completely remove power cable when opening main unit or installing optional devices.

LCD module

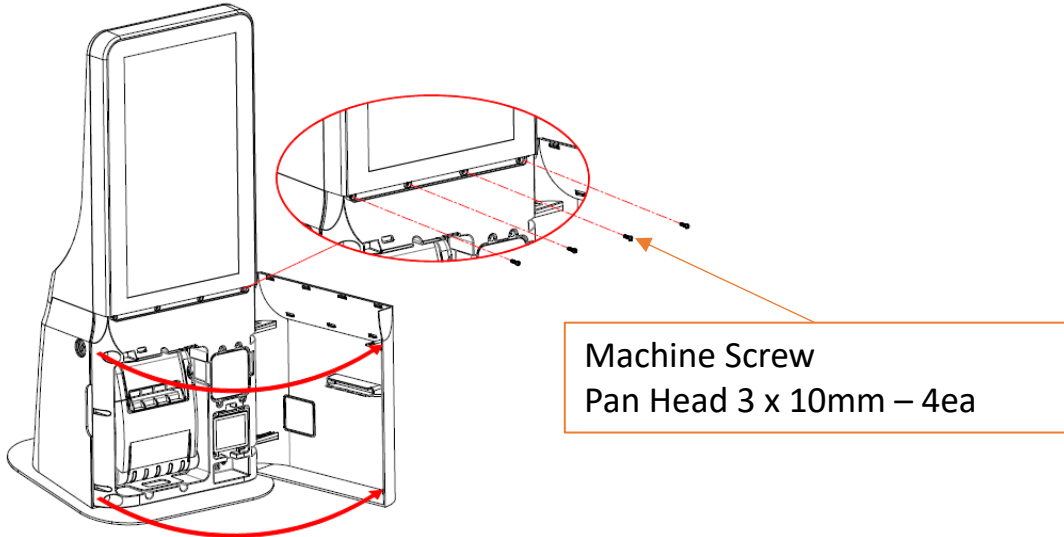

1. Before separating the top and bottom of the product, make sure to turn off the main power switch and disconnect the adapter cord.
2. Open the DOOR and remove the four screws on the DOOR side as shown in the diagram.

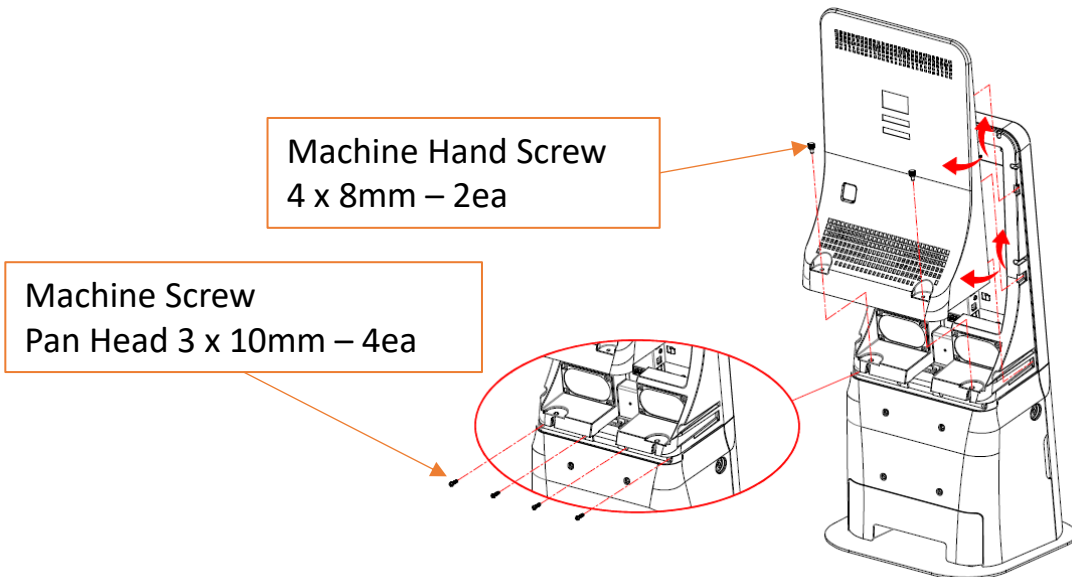

3. After removing the hand screws on the rear cover, please additionally remove the four screws on the top separation part.

Machine Screw
Spring+Washer Pan
Head
4 x 8mm – 1ea

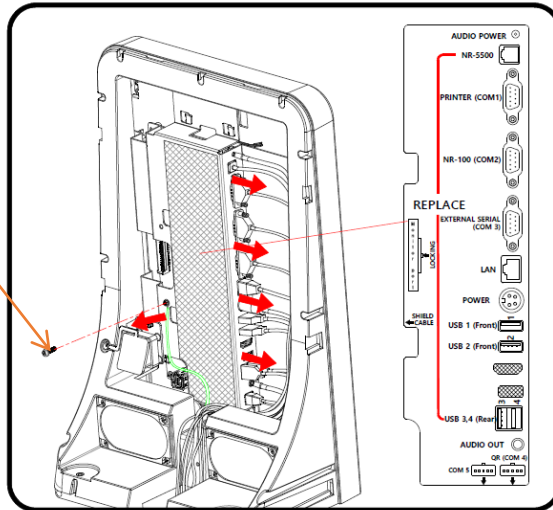

4. Please disconnect the top cable and shield cable from the connector. When disconnecting, only remove the cables in the REPLACE area marked on the sticker and the cable connected to the QR (COM4).

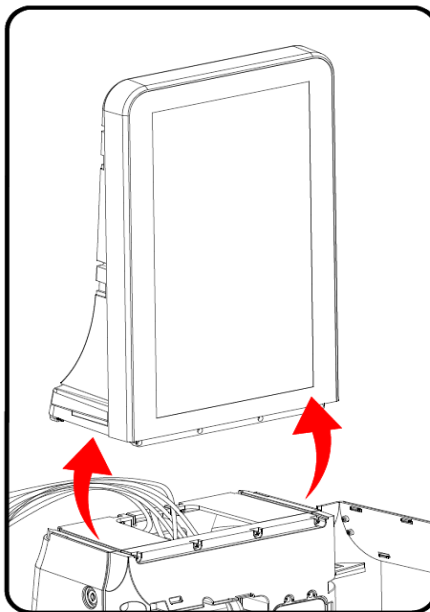

5. Loosen the cable holders and lower the cables downwards.
6. Separate the top part of the product from the bottom.

1. When assembling the top and bottom of the product, be sure to turn off the main power switch and disconnect the adapter cable before proceeding.
2. Align the top part of the product with the bottom part and secure it.
3. Open the DOOR and fasten the four screws on the DOOR side and the four screws on the rear cover side.
4. Connect the cables and shield cables to the connectors in the order indicated by the stickers.
5. Secure the cables in the designated fixing points.
6. Close the rear cover and fasten the hand screws.
7. Reconnect the adapter cable and turn on the main power switch.

(2) Separating Printer module

- Warning : Completely remove power cable when opening main unit or installing optional devices.

Printer module

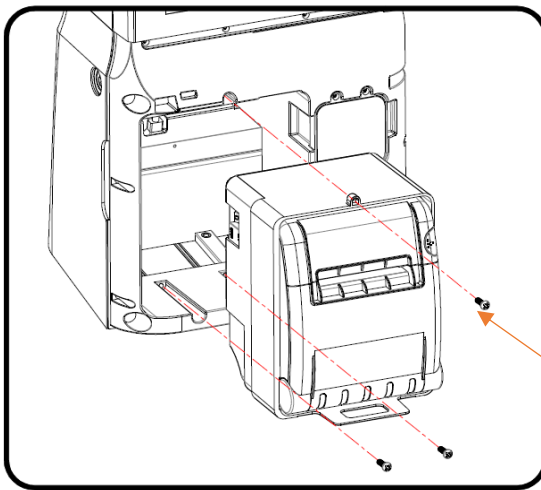
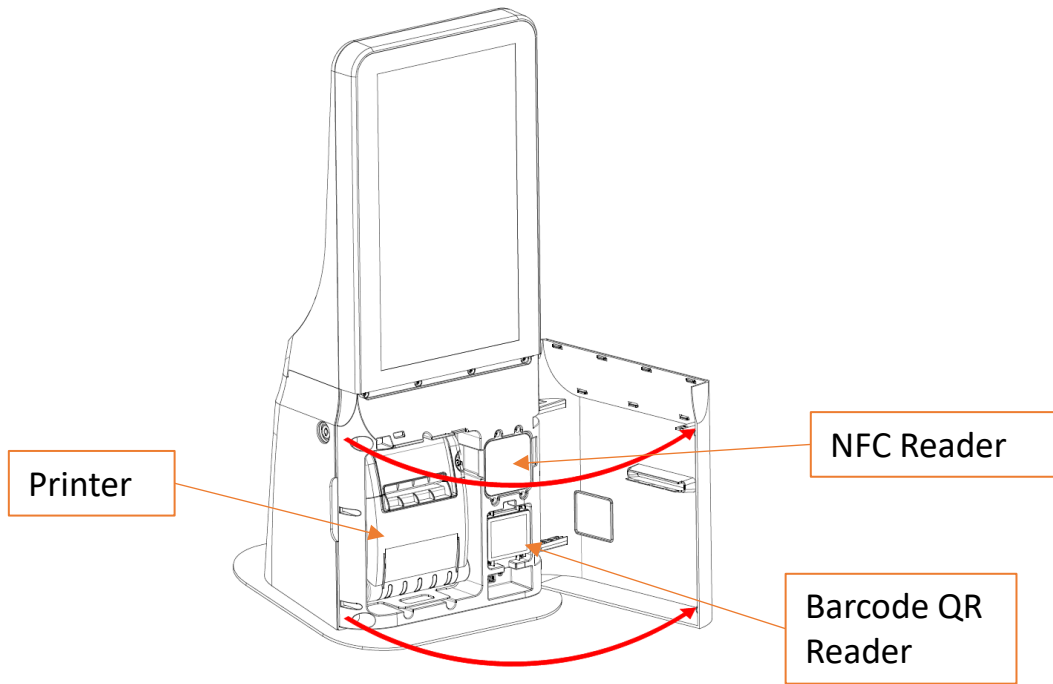

Tapping Screw
Pan Head 3 x 10mm – 3ea

1. Please remove the three screws.
2. Pull the handle to take out the printer.
3. Separate and replace the holder and printer.
4. Ensure that the cable behind the printer (or holder) does not get caught, and insert the printer (or holder) into the main unit.
5. Reattach the screws.

(3) Separating NFC Reader module

- Warning : Completely remove power cable when opening main unit or installing optional devices.

NFC Reader module

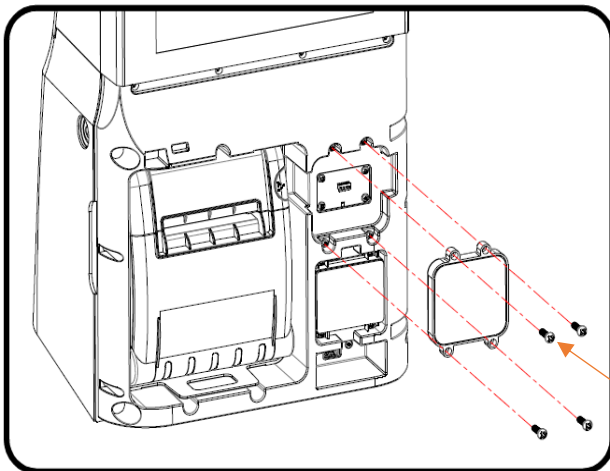
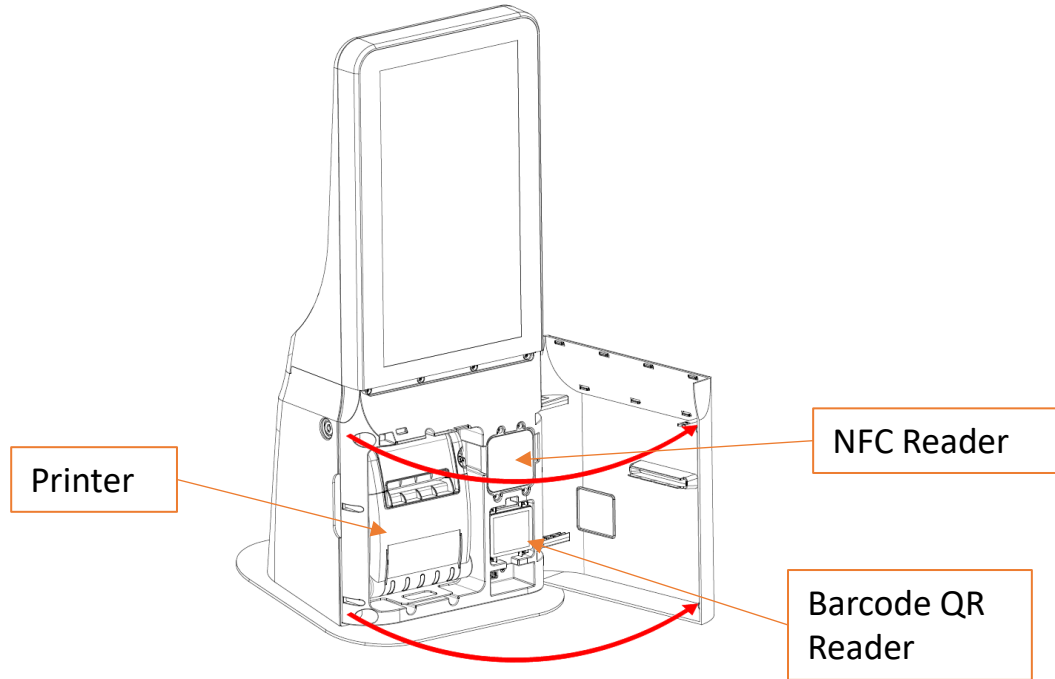

Tapping Screw
Pan Head 3 x 10mm – 4ea

1. Please remove the four screws.
2. Detach the holder.
3. Separate and replace the holder and reader.
4. Install the reader (holder)
5. Reattach the screws.

(4) Separating QR Reader

- Warning : Completely remove power cable when opening main unit or installing optional devices.

QR Reader

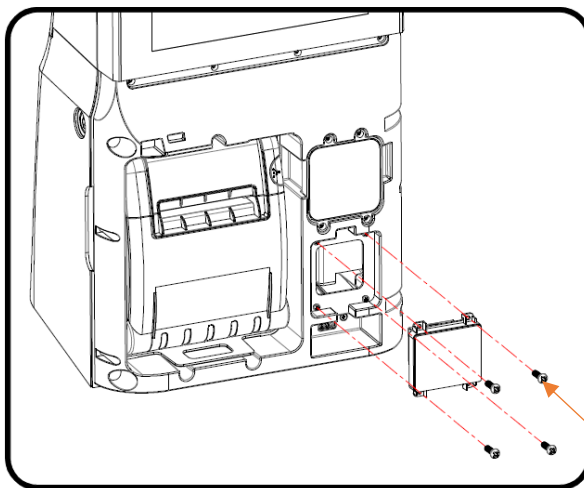
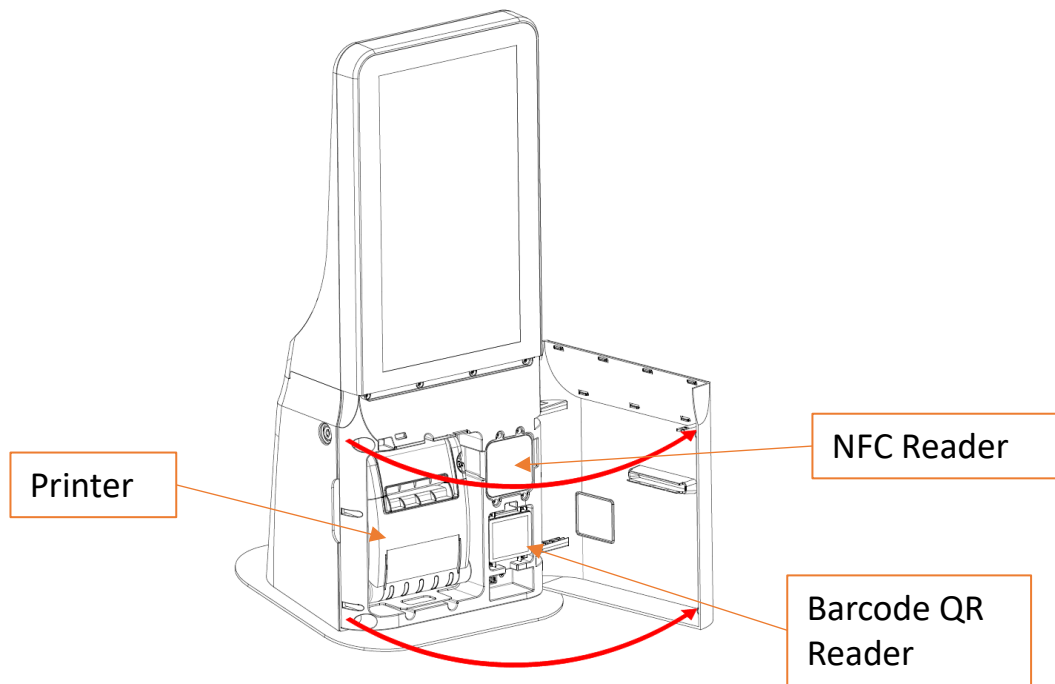

1. Please remove the four screws.
2. Pull out the QR reader.
3. Replace the QR reader.
4. Ensure that the cable behind the reader does not get caught as you insert it into the main unit.
5. Reattach the screws.

(5) Separating Mother board

- Warning : Completely remove power cable when opening main unit or installing optional devices.

Mother Board

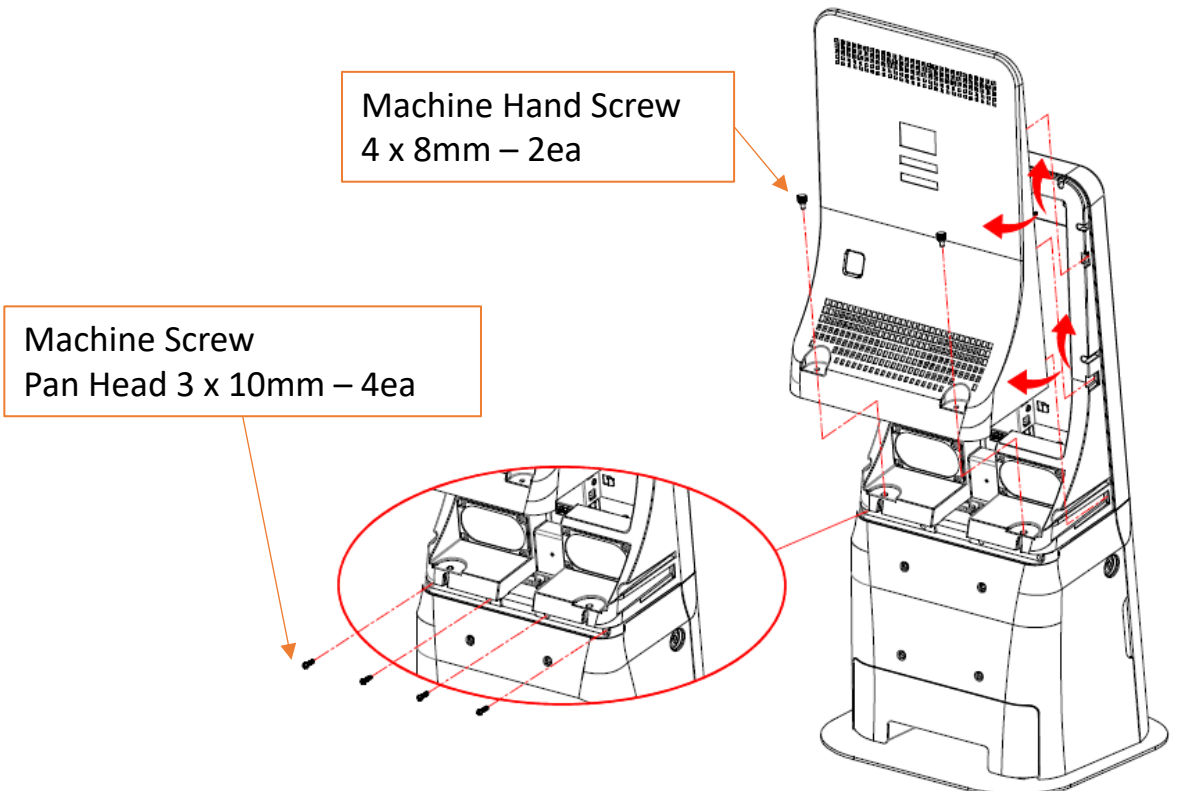
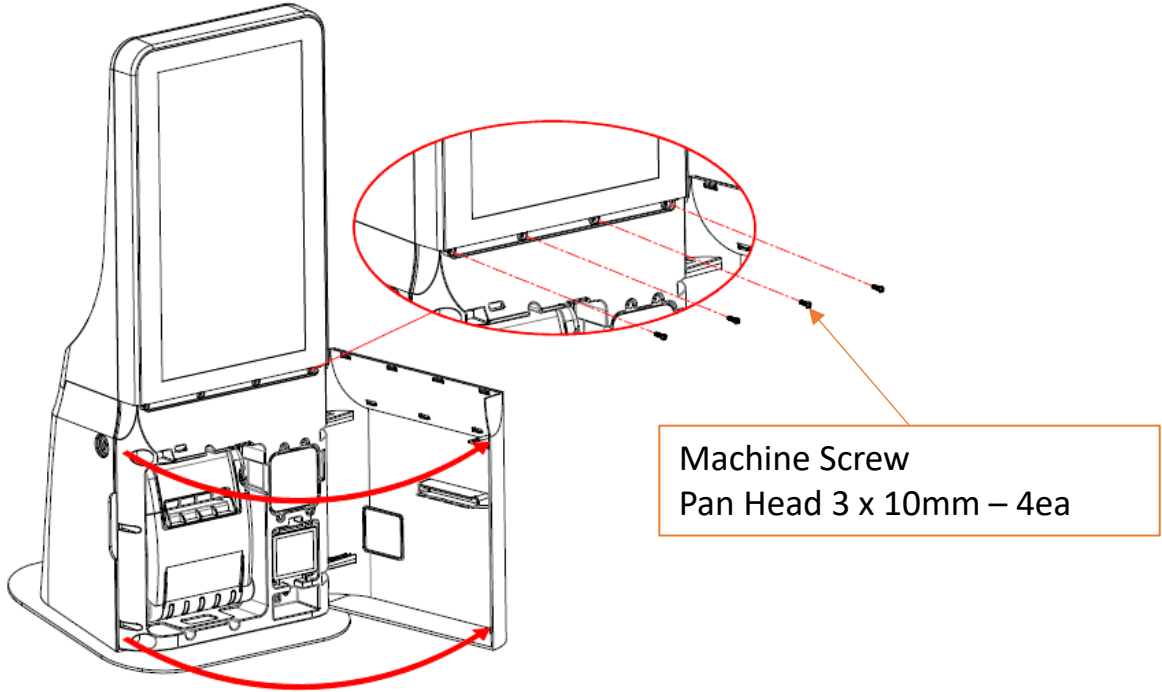

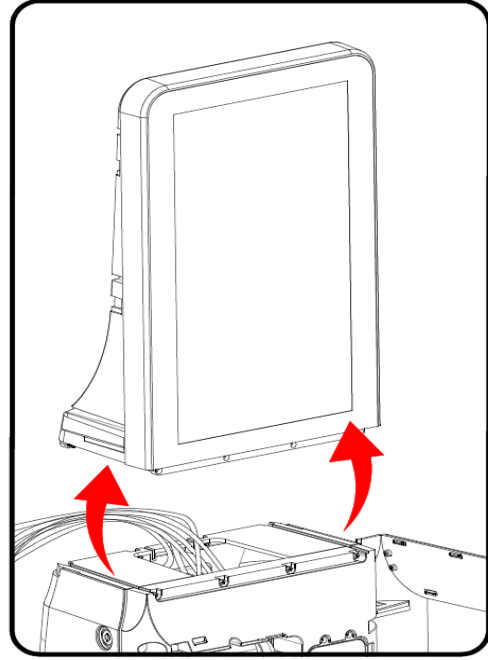
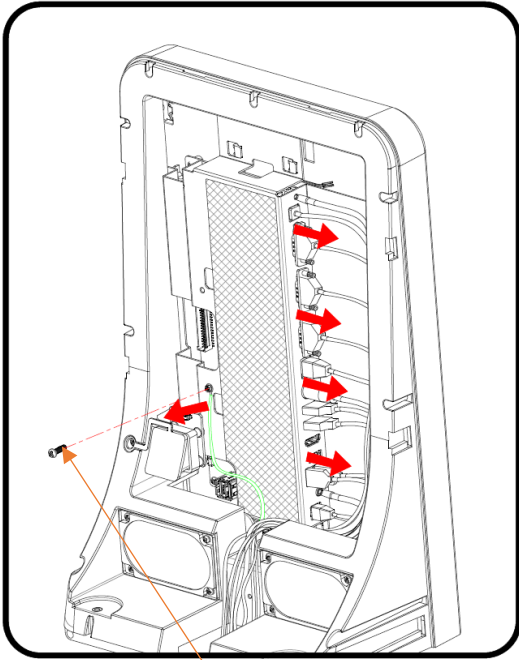

Machine Screw
Spring+Washer Pan Head
4 x 8mm – 1ea

1. After removing the spring washer screws, please disconnect all cables.
2. After organizing the disconnected cables, please lift the monitor upwards and remove it.

Mother Board

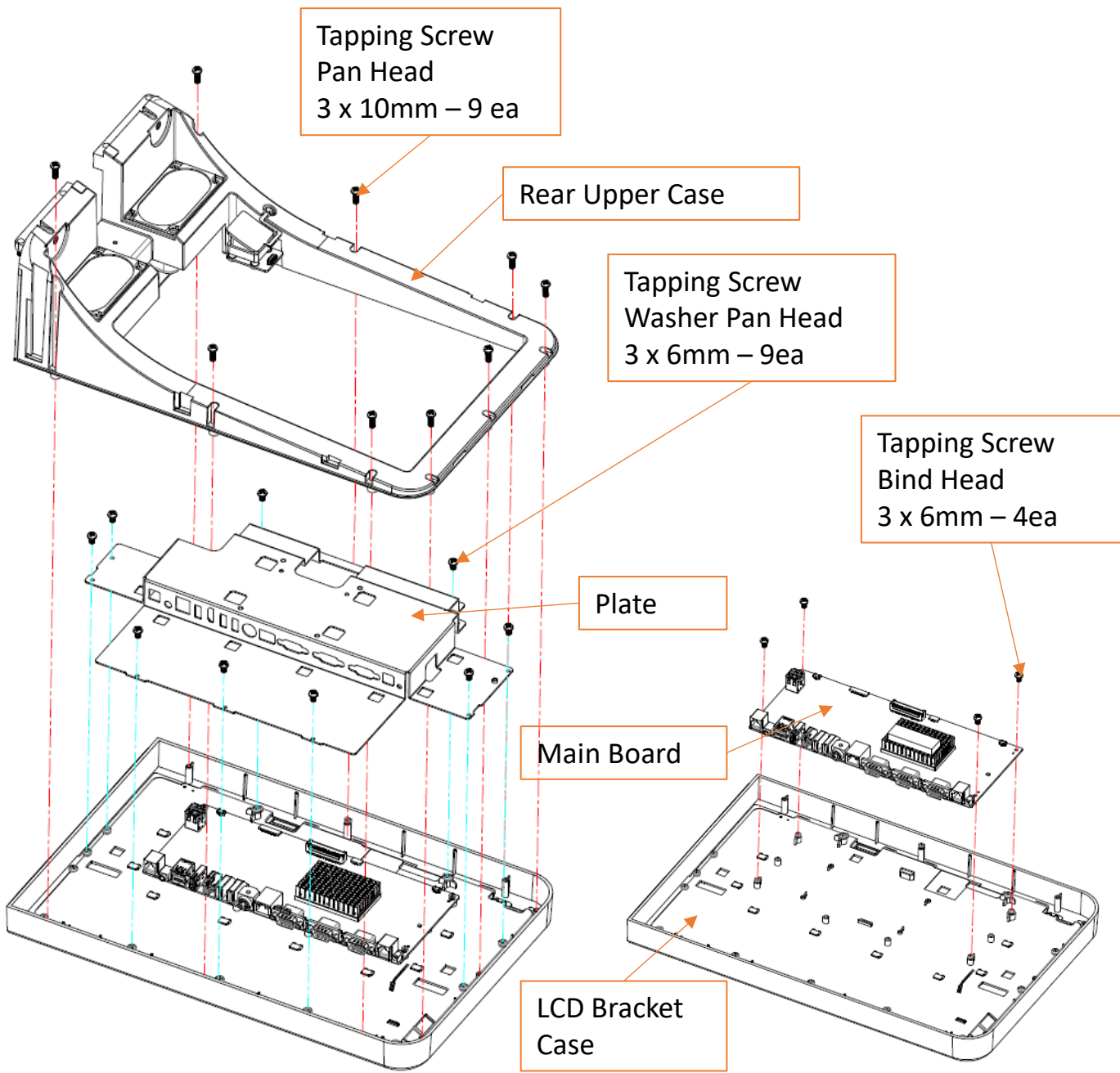

4. Motherboard

(1) Motherboard Overview

This includes description of the jumper and connectors on the motherboard.

Warning

Take note of the following precautions before you install motherboard components or change any motherboard settings.

1. Unplug the power cord from the wall socket before touching any component.
2. Before handling components, use a grounded wrist strap or touch a safely grounded object or a metal object, such as the power supply case, to avoid damaging them due to static electricity.
3. Hold components by the edges to avoid touching the ICs on them.
4. Whenever you uninstall any component, place it on a grounded antistatic pad or in the bag that came with the component.
5. Before you install or remove any component, ensure that the ATX power
6. Supply is switched off or the power cord is detached from the power supply. Failure to do so may cause serious damage to the components or result in electric shock.

(2) Motherboard Layout

This includes description of the jumpers and connectors on the motherboard.

Motherboard view

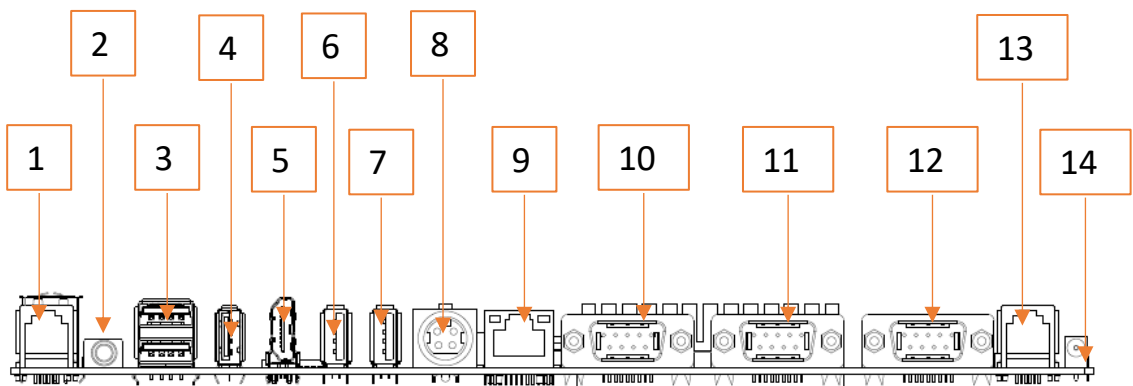
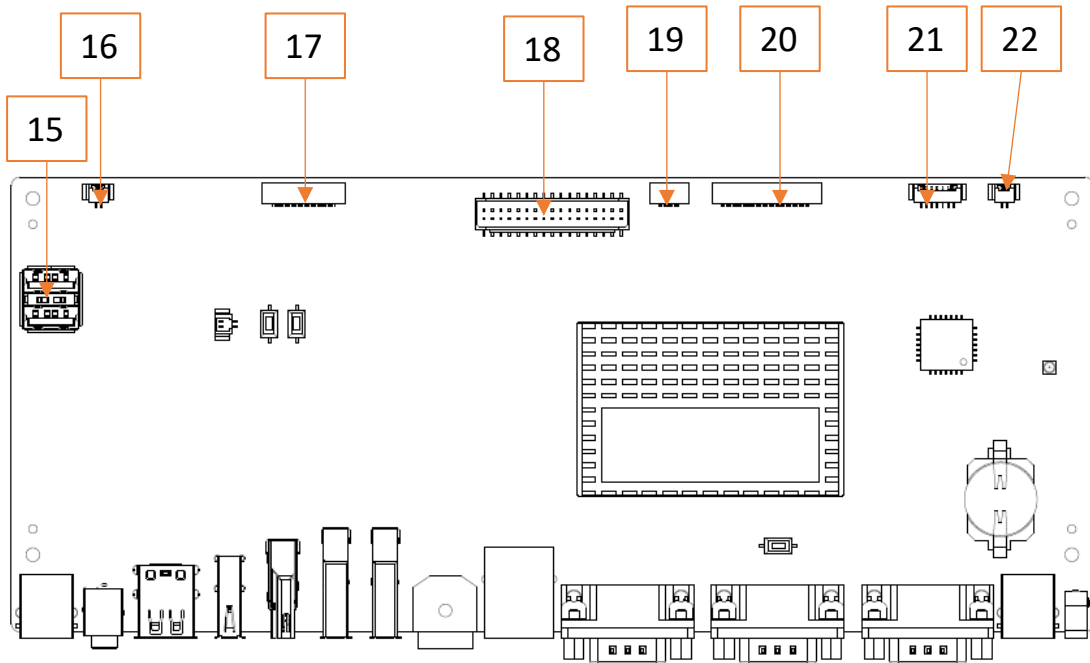

This includes description of the jumpers and connectors on the motherboard.

1. NOT USE
2. Audio JACK
3. USB 2.0 Connector (USB4, USB3)
4. NOT USE
5. HDMI Connector (Option)
6. USB 3.0 Connector (USB2)
7. USB 3.0 Connector (USB1)
8. Main Power Connector
9. Ethernet Connector
10. External Serial Port (COM3)
11. RAY90 (COM2) (NFC Reader)
12. PRINTER (COM1)
13. Serial Port
14. AUDIO POWER
15. NOT USE
16. NOT USE
17. 15.6 inch eDP LCD Connector
18. Secondary LCD Connector
19. Main Display Touch Connector
20. NOT USE
21. Power Switch Connector
22. NOT USE

5. Troubleshooting

(1) Network Issues

Symptom	Corrective Procedure
Cannot access LAN	• Check if hub or switch is working correctly
	• Check RJ45 cable connection
	• Check if LAN LEDs are on/off
	• Reinstall LAN card
	• Replace motherboard

(2) USB Issues

Symptom	Corrective Procedure
USB port doesn't work	• Check Windows device manager for device recognition
	• Check USB device status and connection
	• Erase and re-install USB driver
	• Change USB device

(3) LCD Issues

Symptom	Corrective Procedure
LCD backlight doesn't work	• Check LCD cable connection
	• Check inverter cable connection
	• Replace inverter cable
	• Change LCD panel

(4) Touch-screen Issues

Symptom	Corrective Procedure
Touch-screen doesn't detect touch operations	• Check touch-screen cable connection
	• Check motherboard and LCD cable connection
	• Check BIOS set-up

(5) Power & Booting Issues

Symptom	Corrective Procedure
System switches off abruptly and system does not load	• Check A/C cable connection
	• Check motherboard power connection
	• Check power button cable connection
	• Change power adaptor unit

6. Maintenance

Safety Warning

RAYPOS will not be held responsible for repairs conducted via USER providers other than those officially specified by the seller.

General Guidelines

1. Always disconnect the unit from the power outlet.
2. Disconnect all cables from the POS main unit before attempting repair.
3. Keep all components in the static-proof packaging provided until ready for installation.
4. If the device still is not functioning after repair, please turn off the POS unit and contact the customer USER center at RAYPOS website [www.rayposww.com] for technical consultation.
5. We recommend that power supply unit (PSU) checks and monitor repairs only be performed at a certified USER center.